

# ALC

---

## 40012 BOTTLE BLASTER

---

### OPERATION GUIDE

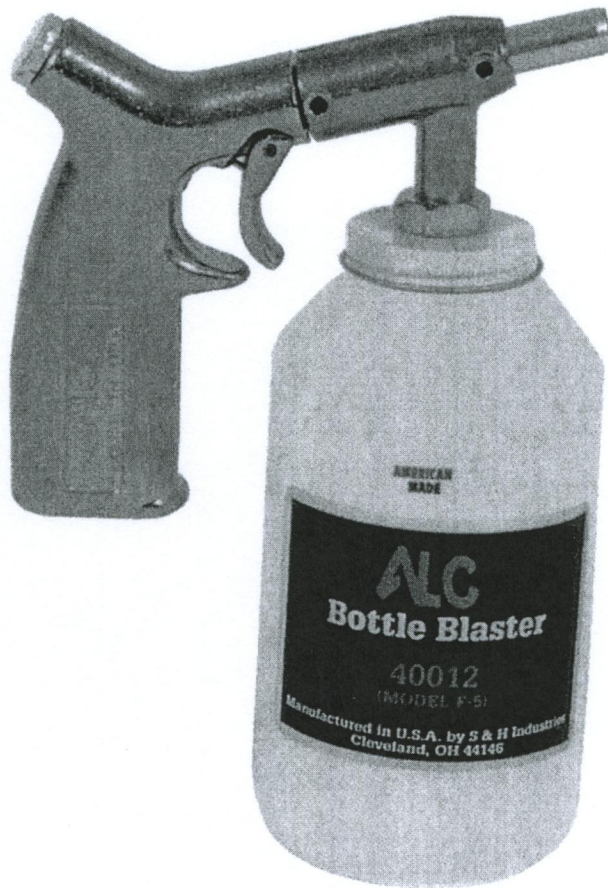

# ALC

DIVISION OF S&H INDUSTRIES  
5200 Richmond Road • Cleveland, OH 44146  
Phone 216-831-0550 • Toll Free 800-253-9726 •  
Fax 216-831-9573

[www.shindustries.com](http://www.shindustries.com)

E-mail: [www.service@shindustries.com](mailto:www.service@shindustries.com)

Rev. 11/26/14

## **WARNING!**

**Do not use an ALC Bottle Blaster until you have read this manual and you understand its contents and warnings. These warnings are included for the health and safety of the operator and those in the immediate vicinity. Keep this manual for future reference.**

Dust created by power sanding, sawing, grinding, drilling, and other construction activities may contain chemicals known to cause cancer, birth defects or other reproductive harm and respiratory illnesses. Some examples of the chemicals include:

- Lead from lead based paints
- Crystalline silica from bricks, cement and other masonry products
- Arsenic and chromium from chemically-treated lumber

Your risk from these exposures varies, depending on how often you do this type of work. To reduce your exposure to these chemicals: Work in a ventilated area, and work with approved safety equipment, such as those dust masks that are specially designed to filter out microscopic particles.

Abrasive blasting produces harmful dust. Everyone in the blasting area must wear a properly fitted and properly maintained NIOSH-approved supplied-air respirator.

### **SILICOSIS AND OTHER DUST WARNINGS:**

**Breathing dust from silica sand may cause silicosis, a fatal lung disease. Breathing dust during blasting operations may also cause asbestosis and/or other serious or fatal diseases. A NIOSH-approved, well-maintained air-supplied abrasive blasting respirator must be used by anyone blasting, anyone handling or using media containing toxic substances or media with more than point one percent (.001) free crystalline silica and anyone in the area of the dust. Harmful dust can remain suspended in the air for long periods of time after blasting has ceased, causing serious injury or death.**

**Before removing respirator, use an air monitoring instrument to determine if atmosphere is safe to breathe. Contact local OSHA or NIOSH office to determine the proper respirator for your particular application.**

**Supplied-Air respirators do not remove or protect against carbon monoxide (CO) or any other toxic gas. Use a carbon monoxide removal device and monitoring device with the respirator to ensure grade D quality air. Follow all applicable OSHA standards and OSHA regulation 1910.134 (d).**

### **OPERATION GUIDE APPLICATIONS**

#### **ABRASIVE BOTTLE BLASTING:**

Your abrasive blaster is designed to spray abrasive material such as coal slag, aluminum oxide, glass beads, steel grit, garnet, ground corncobs, plastic grit, and ground nut shells. The abrasive blasting of rust, paint, scale, grease, old paint, mold, mildew and other corrosion from metal, wood, stone and fiberglass are ideal applications for the abrasive blast cleaner. This product is also excellent for etching distinctive designs in glass, wood, stone, marble and concrete.

## BOTTLE BLASTER SAFETY PROCEDURES

**CAUTION: READ THESE SAFETY PROCEDURES IN THEIR ENTIRETY – PARTS OF THE OPERATING INSTRUCTIONS ARE WITHIN THESE WARNINGS.**

These procedures are not intended to be exhaustive due to the many variables in the abrasive blasting field. Therefore, we **INSIST** that the hands, ears, mouth, nose and eyes be covered with appropriate safety protection at all times.

### **ADDITIONAL WARNINGS! CAUTION MUST BE EXERCISED BY USER AT ALL TIMES**

1. **Everyone in the blast area including the equipment operator should correctly use and maintain a NIOSH-approved air-supplied respirator, even after blasting has ceased. Harmful dust can remain suspended in the air for long periods of time after blasting has ceased causing injury or death.**
2. **Before using the bottle blaster: Put on eye protection, gloves, and NIOSH-approved respirator. Always wear these protective items when operating and while servicing your bottle blaster. A well maintained air supplied blasting respirator must be used by anyone blasting.**
3. **Use thick gloves with gauntlets to protect your hands.**
4. **Use backboards to prevent overspray from hitting someone or something else because the dust will travel a long distance. Blast in a large open area to minimize abrasive accumulation in surrounding areas.**
5. **For safe operation, perform recommended preventive maintenance on bottle blaster and accessories. Replace all worn parts before they fail. Immediate replacement of worn components is required. Failure to replace worn components could result in exposing the operator or bystanders to high speed media and compressed air, causing serious injury.**
6. **Do not use corrosive materials of any type in unit. Use only clean, dry media.**
7. **Always place the bottle blaster so that the outlet is pointed away from any objects or persons. Stand clear of the path of exiting abrasive. It may come out at high velocity. Impact from exiting abrasive could cause severe injury.**
8. **Static electricity can be created by the use of this equipment. Do not use within fifty feet of any explosive, potentially explosive substances, or their vapors as an explosion can occur.**
9. **Do not use this equipment in any area that might be considered hazardous or where flammable gases or liquids are present. Failure to do so may cause an explosion resulting in serious injury.**

#### **OPERATION**

Remove quart bottle from the blast gun assembly and fill with your desired abrasive material or liquid. Connect your air supply to the handle of the blast gun with a 1/4" NPT fitting (not supplied). Abrasive materials must be dry and preferably of the finest grit available to prevent clogging of the gun.

The Abrasive bottle blaster is designed to operate between 50–110 PSI. Pressures of no more than 70 PSI are recommended for the etching of glass or plastic and the carving of wood. A minimum 2-3 H.P. compressor is required. At 80 PSI the 1/4" nozzle supplied with the product will require 15 CFM. A smaller nozzle requiring only 7 CFM can be ordered separately. For maximum operating power, no less than 5/16" I.D. air hose of a maximum 50 feet in length with no splices or restrictions should be connected to a direct line from the compressor tank to the blast gun.

The speed and quality of the blasting depends upon the size of the air jet and nozzle used, air pressure, type and size of abrasive, and distance from the work surface. The gun should be held almost directly at the object to be cleaned, but at enough angle that the abrasive doesn't rebound at the operator. Abrasive power is increased as you hold the gun closer to the work.

### **WARNING!**

**Disconnecting hose while unit is under pressure could cause serious injury or death. Use safety lock pins and safety cables in all coupling connections to help prevent hose couplings from accidental disconnection.**

**If twist-on type air hose couplings are used, they must be secured by safety lock pins or wires to prevent accidental disconnection while under pressure. Hose disconnection while under pressure could cause serious injury.**

### **MAINTENANCE**

Replace the nozzle when you notice too much air and abrasive or liquid escaping, or if cleaning speed is reduced. When the air jet is worn, it will deflect the flow downward and will cut a groove in the nozzle. There are optional ceramic nozzles and Tungsten Carbide that last longer. If air jet and nozzle are not replaced when worn, the suction head will become damaged.

The nozzle is easily replaced by loosening the nozzle set screw. The air jet is accessible by removing the suction head. To obtain maximum power, the I.D. of the air jet must be 1/2 the I.D. of the nozzle. When re-assembling the blast gun, ensure that the suction head is holding the air jet and rubber sealing washer tightly against the gun body. Tighten the set screw securely, making sure that it is sitting in the proper groove on the gun handle. Also, periodically check the abrasive hose for leaks or cracks.

**IMPORTANT: Nozzle and air jet must maintain proper size ratio, i.e. small/Gold, medium/silver, large/Black. We recommend that you rotate your nozzle approximately every thirty minutes and to replace the air jet after every third or fourth nozzle replacement.**

### **Abrasive (Media) Usage:**

1. If moisture is in the media, it will eventually plug the system. Keep the media and compressor air dry to avoid this problem.
2. If the media is moist, screen it and dry it before using.
3. Do not leave media in the bottle after blasting because it can absorb moisture and impair blasting performance.
4. Store media in a dry place; keep media off the ground or concrete floors. Put it on a wooden skid.
5. If the humidity is excessively high it may not be advisable to blast at that time.

6. Consider using different grades or different types of media to prevent nozzle clogging due to high moisture content.
7. Do not use sand

ABRASIVE AND PRESSURE GUIDE					
Material to Be Cleaned	Air Pressure	Abrasive		Grit Size	
Steel vats	100-125 psi	Coal Slag	Garnet	30/50	20/40
Auto fenders	50-80 psi	Coal Slag	Garnet	80/120	20/40
Brick and block	80-125 psi	Coal Slag	Garnet	30/50	20/40
Steel cabinets	80-125 psi	Coal Slag	Garnet	30/50	20/40
Truck bodies	100-125 psi	Coal Slag	Garnet	30-50	20/40
Glass etching	50-70 psi	Glass beads	Aluminum Oxide	30/40	100
Wood	50-70 psi	Nut shells	Glass beads	14/30	30/40

**REPLACEMENT PARTS AND ACCESSORIES**

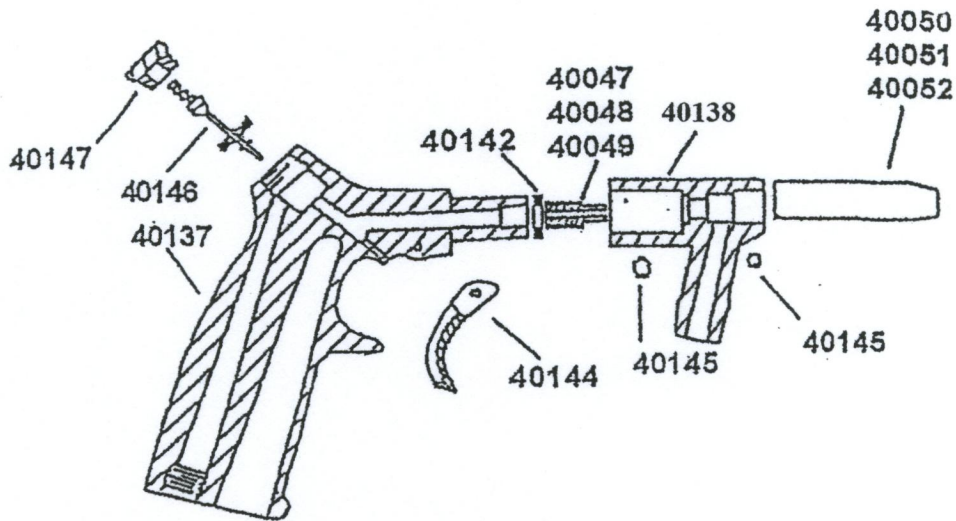

**REPLACEMENT PARTS**

Part No.	Description
40136	Blast gun handle only, with trigger and valve
40141	Blast gun siphon head only, with nozzle and air jet (threaded)
40159	Bottle assembly only, complete
40156	Bottle only, 31 oz.
40158	Siphon tube
40160	Lock nut, 5/8-18
40161	Bottle lid, for threaded siphon head
40142	Washer
40144	Blast gun trigger
40145	Blast gun set screw
40146	Blast gun valve, spring and seat assembly
40147	Valve nut

40048	1/8" Air jet (silver), 15 CFM
40051	1/4" Steel nozzle (silver), 15 CFM

### OPTIONAL ACCESSORIES "NOT INCLUDED"

Part No.	Description	Part No.	Description
40047	5/64" Air Jet (Gold), 7 CFM	41905	Standard Strainer
40049	5/32" Air Jet (Black), 20 CFM	41907	Funnel Strainer
40050	13/64" Nozzle (Gold), 7 CFM	41908	Fine Mesh Strainer
40052	5/16" Nozzle (Black), 20 CFM	41909	Small Parts Blasting Basket
40056	13/64" Ceramic Nozzle, 7 CFM	41910	Small Parts Blasting Tray
40057	1/4" Ceramic Nozzle, 15 CFM		
40058	5/16" Ceramic Nozzle, 20 CFM		

#### Coal Slag #40093

Coal Slag is used when paint and rust has to be removed from steel, such as car bodies, tanks or heavy machinery. Coal Slag is faster cutting, can be re-used, is moisture free, and will not pack or absorb moisture. (25 Lb. container)

#### Steel Grit #40109

Steel grit is extremely fast cutting on rusty metal and hard to remove paint. Steel Grit is popular because it leaves a very smooth finish. It is also comparable in price to most other specialty abrasives. Steel Grit is recommended in reclaim systems or cabinets. (25 Lb. container)

#### Glass Bead #40105

Glass Bead is used in creating a satin or matte finish. Glass Bead is recommended in reclaim systems or cabinets. (25 Lb. container)

#### Aluminum Oxide #40098

Aluminum Oxide is a high quality abrasive that is sharper than sand (not recommended) and cuts twice as fast as sand. It leaves a smooth textured finish with no pits or burrs. Aluminum Oxide is rougher than glass bead and can be used over and over again. It is one of the most economical abrasives you can use in any reclaim systems or cabinets. (4/25 Lb. container)

#### Plastic Grit #40110

Primarily used to strip aluminum and fiberglass. Great for stripping paint, light oxidation and surface rust. Recommended for use in blast cabinets because it creates very little dust. Works quickly, last a long time and increases visibility within the cabinet. (10 Lb. container)

#### Walnut Shells #40112

Walnut shells are recommended for use on "soft" surfaces such as aluminum, glass, wood, and other areas where no pitting is desired. Leaves a smooth, dull finish. (10 Lb. container)

**Garnet #40126**

Garnet is a multi-purpose abrasive. It is sharp and fast cutting with low dust. Recycles well. Great for cabinet blasting. Leaves smooth textured finish like Aluminum Oxide.

**TROUBLESHOOTING TIPS****PROBLEM/CAUSE****POSSIBLE SOLUTION****Surging of blast flow:**

Air pressure too low  
Too much media

Check pressure gauge on compressor

**Excessive media consumption:**

Media valve open too far  
Air pressure too low

Close slightly  
Check pressure gauge on compressor

**Clogging and plugging of blast flow:**

Debris in media  
Media size too large  
Nozzle plugs  
Nozzle plugs  
Wet media

Purge and screen  
Use smaller grit size  
Use larger nozzle  
Adjust media valve 40200  
Dry media, drain water from air

**Moisture in abrasive media:**

Wet media  
Water in air  
Water in tank

Change or use dry media  
Drain water from air lines  
Empty, dry out and refill

**Humid weather:**

Moderate humidity  
Moderate humidity  
High humidity

Keep media as dry as possible  
Use drier or moisture separator  
Avoid that period of use if possible

**Overtaxed compressor:**

Compressor too small  
Nozzle size too large  
Too many leaks in plumbing  
Holes in abrasive hose  
Air filter on compressor plugged

Restrict time used  
Use smaller size  
Seal and tighten plumbing  
Replace hose  
Clean

**Lack of air pressure:**

Compressor too small  
Supply valves not on full position  
Nozzle size too large  
Leaks in plumbing  
Holes in abrasive hose  
Air filter on compressor plugged  
Urethane gasket worn or dirty

Use smaller nozzle  
Open valves  
Use smaller size  
Seal and tighten plumbing  
Replace hose  
Clean filter  
Clean or replace gasket

**Lack of abrasive flow:**

Blaster tank empty  
Moisture in media  
Not enough air pressure

Fill tank (6" from top)  
Dry media  
Check system

Abrasive hose kinked  
Debris in media

Straighten hose  
Clean or screen media

**Disclaimer of Warranties.** S & H Industries, Inc. ("Seller") makes no warranties with respect to any goods delivered to Buyer or users except as specifically set forth within this manual. S & H INDUSTRIES, INC. MAKES NO IMPLIED WARRANTIES OF MERCHANTABILITY OR FITNESS FOR A PARTICULAR PURPOSE WITH RESPECT TO ANY OF THE GOODS, AND S & H INDUSTRIES, INC. EXPRESSLY DISCLAIMS ANY IMPLIED WARRANTIES AGAINST INFRINGEMENT. S & H INDUSTRIES, INC. WARRANTIES SHALL NOT APPLY TO ANY DAMAGE OR NON-CONFORMITY RESULTING FROM THE NEGLIGENCE OF IMPROPER ASSEMBLY OR USE OF ANY GOODS BY USERS OR BUYER OR ITS EMPLOYEES OR AGENTS, OR FROM ALTERATION OR ATTEMPTED REPAIR BY ANY PERSON OTHER THAN S & H INDUSTRIES, INC. ALL USED, REPAIRED, MODIFIED OR ALTERED ITEMS ARE PURCHASED AS-IS AND WITH ALL FAULTS.

**Indemnification Agreement.** Buyer agrees, to the fullest extent permitted by the law, to fully indemnify, hold harmless, and defend Seller, its parent, subsidiary, and affiliated companies, its owners, officers, directors, employees, agents, representatives and insurers (collectively, "Indemnities") from and against any and all claims, demands, suits, damages, judgments of sums of money, losses and expenses, including but limited to attorney's fees and costs (collectively "referred to herein as "Claims") arising out of or resulting from any bodily injury, sickness, disease or death or injury to or destruction of tangible property, arising out of or resulting from the use, sale or distribution of any and all products purchased from Seller by Buyer, regardless of whether or not such claim arises in whole or in part out of Seller's alleged fault, including but not limited to Seller's negligence, strict liability, products liability, breach of warranty or any other act or omission. Buyer expressly waives any and all immunity from suit by Seller, its parent, subsidiary, and affiliated companies, and its owners, officers, directors, employees, agents, representatives and insurers, by operation of any workers' compensation law or statute. **By purchasing from S & H Industries, Inc., Buyer acknowledges and represents that Buyer has read, fully understands and agrees to the Indemnification provisions set forth above.**

#### LIMITED WARRANTY

S & H Industries, Inc. warrants this product to be free from defects in materials or workmanship for two years after the date of original purchase.

If the product should become defective within that warranty period, we will repair or replace it (at our option) free of charge including return transportation to you provided you deliver it prepaid to S & H Industries, Inc. 5200 Richmond Road, Bedford Hts., Ohio 44146.

This warranty does not include damage resulting from accident, abuse or misuse of the product. Nor does it apply to parts subject to abrasive wear, i.e., nozzles, air jets, seal blocks, valves, hose connections and hoses.

Implied warranties including those of merchantability and fitness for a particular purpose are excluded to the extent permitted by law, and any and all implied warranties are excluded. This is the exclusive remedy and liability for consequential damages under any and all warranties are excluded to the extent exclusion is permitted by law.