

5 GALLON

ABRASIVE BLASTER

OPERATING AND MAINTENANCE INSTRUCTIONS



5200 Richmond Road • Cleveland, OH 44146
Phone 216-831-0550 • Toll Free 800-253-9726 •
www.shindustries.com
(revised date of 2/13/2012)

WARNING!

DO not use a Pressure Blaster until you have read this manual and you understand its contents and warnings. These warnings are included for the health and safety of the operator and those in the immediate vicinity. Keep this manual for future reference.

Dust created by power sanding, sawing, grinding, drilling, and other construction activities may contain chemicals known to cause cancer, birth defects or other reproductive harm and respiratory illnesses. Some examples of the chemicals include:

- **Lead from lead based paints**
- **Crystalline silica from bricks, cement and other masonry products**
- **Arsenic and chromium from chemically-treated lumber**

Your risk from these exposures varies, depending on how often you do this type of work. To reduce your exposure to these chemicals: Work in a ventilated area, and work with approved safety equipment, such as those dust masks that are specially designed to filter out microscopic particles.

Abrasive blasting produces harmful dust. Everyone in the blasting area must wear a properly fitted and properly maintained NIOSH-approved supplied-air respirator.

SILICOSIS AND OTHER DUST WARNINGS:

Breathing dust from silica sand may cause silicosis, a fatal lung disease. Breathing dust during blasting operations may also cause asbestosis and/or other serious or fatal diseases. A NIOSH-approved, well-maintained air-supplied abrasive blasting respirator must be used by anyone blasting, anyone handling or using media containing toxic substances or media with more than **point one percent free crystalline silica and anyone in the area of the dust, Harmful dust can remain suspended in the air for long periods of time after blasting has ceased, causing serious injury or death.**

Before removing respirator, use an air monitoring instrument to determine if atmosphere is safe to breathe. Contact local OSHA or NIOSH office to determine the proper respirator for your particular application.

Supplied-Air respirators do not remove or protect against carbon monoxide. If atmosphere is safe to breathe. Contact local OSHA or NIOSH office to Determine the proper respirator for your particular application.

Supplied-Air respirators do not remove or protect against carbon monoxide (CO) or any other toxic gas, Use a carbon monoxide removal device and Monitoring device with the respirator to ensure grade D quality air. Follow All applicable OSHA standards and OSHA regulation 1910.134(d).

SPECIFICATIONS

Tank Volume	5 gallon
Hose Length:	8 feet
Working Pressure	60-110 PSI
Air Consumption:	6-25cfm
Overall Dimensions:	13-3/8" × 15-3/4" × 30-25/32"
Weight:	27 lbs

SAVE THESE INSTRUCTIONS

You will need these instructions for the safety instructions, the operating procedures, the parts list and the warranty. Put them in a safe and dry place for future reference.

IMPORTANT SAFETY INSTRUCTIONS

WARNING: When using tools such as your air compressor, whether powered by electric motor or gasoline engine, basic safety precautions should always be followed to reduce the risk of fire, electric shock, and personal injury.

You should review the safety instructions for your air compressor before beginning abrasive blasting with this tool.

PRESSURE BLASTER SAFETY PROCEDURES

CAUTION: READ THESE SAFETY PROCEDURES IN THEIR ENTIRETY-- PARTS OF THE OPERATING INSTRUCTIONS ARE WITHIN THESE WARNINGS.

These procedures are not intended to be exhaustive due to the many variables in the abrasive blasting field. Therefore, we **INSIST** that the hands, ears, mouth, nose and eyes be covered with appropriate safety protection at all times.

ADDITIONAL WARNINGS!

CAUTION MUST BE EXERCISED BY USER AT ALL TIMES

- 1. Do not place fingers, any body parts or any components in the filler plug seal area when the blast machine is being pressurized. Failure to keep body parts from the filler plug area will result in serious injury.**
- 2. Do not exceed maximum working pressure of 110 PSI. Failure to keep maximum working pressure below 125PSI can cause the blast machine to burst, causing death or serious injury.**
- 3. Everyone in the blast area including the equipment operator should correctly use and maintain a NIOSH-approved air-supplied respirator, even after blasting has ceased. Harmful dust can remain suspended in the air for long periods of time after blasting has ceased causing injury or death.**
- 4. Before using the pressure blaster: Put on safety glasses, gloves, and NIOSH-approved respirator. Always wear these protective items when operating and while servicing your abrasive blaster. While a protective hood is provided to help protect you from flying particles as you use the machine, the hood does not provide protection from air borne particles. A well maintained air supplied blasting respirator must be used by anyone blasting.**
- 5. Use thick gloves with gauntlets to protect your hands.**
- 6. Use backboards to prevent overspray from hitting someone or something else because the dust will travel a long distance. Blast in a large open area to minimize abrasive accumulation in surrounding areas.**
- 7. Do not pull media tank around by the abrasive hose or let tank fall over as a fitting may break rendering the machine unsafe. Media and air under 110 PSI has a very high destructive force. Never leave a pressurized machine unattended. If an emergency occurs, such as a burst blast hose, shutdown the machine immediately.**
- 8. Drain air out of tank through the inlet valve and disconnect power before maintenance cleaning of any kind. When removing nozzle, caution must be exercised as air pressure may still be in the hose if the nozzle is plugged.**

9. For safe operation, perform recommended preventive maintenance on blaster tank, remote unit and accessories. Replace all worn parts before they fail. Immediate replacement of worn components is required. Failure to replace worn components could result in exposing the operator or bystanders to high speed media and compressed air, causing serious injury.
10. Do not use corrosive materials of any type in unit. Use only clean, dry media.
11. Do not splice abrasive hose. The splice will wear out quickly and may violently spray media over the surrounding area. A worn blast hose could suddenly fail by bursting, Couplings and nozzle holders may not adequately grip worn hose, causing them to blow off under pressure. Compressed air and abrasive escaping from a burst hose, or disconnected coupling or nozzle holder could cause severe injury.
12. Welding, grinding, or drilling on the blast machine could weaken the vessel. Compressed air pressure could cause a weakened blast machine to rupture, resulting in death or serious injury.
13. Always place the machine so that the outlet is pointed away from any objects or persons. Stand clear of the path of exiting abrasive. It may come out at high velocity. Impact from exiting abrasive could cause severe injury.
14. Static electricity can be created by the use of this equipment. Do not Use within fifty feet of any explosive, potentially explosive Substances, or their vapors as an explosion can occur.
15. Do not use this equipment in any area that might be considered hazardous or where flammable gases or liquids are present. Failure to do so may cause an explosion resulting in serious injury.
16. Do not overfill tank with media. Do not fill to within 6 inches from top of the tank.
17. BEFORE OPENING THE TANK, release the air pressure on the abrasive tank. To do this, turn off the air supply valve (31), and push down to open the DEADMAN valve (25), to release pressure in the line. Ensure that the tank pressure gauge (9) reads zero, then open the tank.
18. MAINTAIN CORRECT AIR PRESSURE, maximum of 110 PSI is recommended, pressure must not exceed 125 PSI. If pressure exceeds 125 PSI, stop all work immediately, and disconnect the air compressor to reduce the excess pressure. Do not investigate the blaster's pressure problem until the pressure gauge (9), reads zero.

ASSEMBLING THE ABRASIVE BLASTER

1. Refer to the drawing for step 1, assembling the intake manifold (12). First, attach the pressure gauge (9), to the top of the intake manifold, turning the gauge so that it can be seen across the top of the tank. Next, attach the throttling valve (31) to the bottom of the manifold. Attach the nipple connector, to the throttling valve. Attach the joint pipe (10), to the manifold.
2. Refer to the drawing for step 2, to assemble the water trap filter (9). Nipple connector (11) is screwed into each side of the filter. On one side, attach the air supply valve (31), to the nipple connector (10), and then attach the male/female connector (8), to the other side of the air supply valve. When you're ready to operate the abrasive blaster, the air hose from the compressor will fasten to the male/female connector (8).
3. Place the tank (15) on a table with the four clips up. Refer to the drawing for step 3. Screw the water trap filter (9) and its parts into the hole at the side of the intake manifold. Then screw the open end of the joint pipe (10) with intake manifold (12) and pressure gauge (9) attached into the threaded hole on the side of the filler pipe on top of the tank. Again, be sure that the manifold and gauge are vertical.
4. Refer to the drawing for step 4, assembly of the abrasive outlet valve into the hole at the bottom of the tank; Attach four parts, in order: Nipple connector (11); abrasive metering valve (30); nipple connector (11) and the abrasive outlet pipe (12).
5. Refer to the drawing for step 5, assembly of the nozzle DEADMAN valve (25). In this assembly process, you'll select one of the four nozzles (27). This is not a permanent selection, as you may change nozzles according to the job being done. Screw the adapter (23), into the nozzle DEADMAN valve (25). Screw the gasket (26) into the nipple connector, then add a nozzle (27) and the nozzle cap-nut (28).
6. Refer to the drawing for step 6, for connecting the abrasive metering valve assembly and the assembly. Slide the two hose clamps (22), over each end of the abrasive hose (21), press one end of the hose, over the nipple on the abrasive outlet pipe (12) and the other end over the adapter (23). Both hose ends should be firmly seated on the nipples. Slide the hose clamps along the hose to each nipple and tighten the clamps very firmly.
7. Fasten the two handlebars (06) to the tank using four pan screws (02) and four washers and four hex nuts. Note: keep the handle curve ends upward.
8. Locate the axle (29), and slide it through the holes in the sides of the handlebars (06). Place one wheel (16) at each end of the axle and fasten them into place with cotter pins (14) and washer (34).
9. Insert the fixed foot (17) onto the fitting on the bottom of the tank near the edge. Use your last cotter pin (14) to hold the foot to the tank.
10. Before beginning operations, go back over each connection, double checking to ensure that all are tight and properly seated.

MAINTENANCE

WARNING!

Failure to observe the following before performing any maintenance could cause serious injury or death from the sudden release of compressed air:

- **Depressurize the blast machine.**
- **Disconnect power supply.**
- **Lockout and tag out the compressed air supply.**
- **Bleed the air supply line to the blast gun.**

Immediate replacement of worn components is required. Failure to replace worn components could expose the operator or bystanders to high speed media and compressed air could cause death or serious injury.

Leaks around couplings and nozzle holders indicate worn or loose fitting parts. Nozzle holders and couplings that do not fit tightly on hose and nozzles that do not fit tightly in nozzle holders could disconnect while under pressure. Impact from nozzles, couplings, hoses, or abrasive, and parts disconnected while under pressure could cause severe injury.

To ensure a long and efficient operational life of the Deadman Handle, it is highly recommended that the following procedures be followed:

- 1. Periodically(after 5-6 months of moderate use or after 10-15 hours of heavy industrial use) replace all hose adaptors that are for abrasive flow use only.**
- 2. Periodically replace sealing block in deadman handle to maintain proper shut-off.**
- 3. Replace abrasive hose when it begins to soften or leaks media or air around the hose or handle area.**
- 4. Replace the nozzle when it wears to the next larger size.**
- 5. Adjustment of sealing block may be required after nozzle change.**

OTHER MAINTENANCE ITEMS:

- 1. You should make every effort to protect your air compressor from any damage it may receive from your abrasive blasting work. Your best option is to keep the compressor up wind from the abrasive blasting, and the greater the distance between them, the better. Other than that, you should continue standard maintenance procedures for the compressor.**
- 2. Some parts of the abrasive blaster will wear much more rapidly than others, the parts needing close attention carry the air/abrasive mixture, starting with the abrasive hose (21) and going through the metal fillings, the DEADMAN valve (25) and the ceramic nozzles (27).**
- 3. If air leaks develop in any of these parts, you should stop all work ,and find what needs to be repaired or replaced. When it's new, the abrasive hose (21) has 2 cord piles and the walls are 1/4" thick. As the interior diameter is abraded, this wall becomes thinner and thinner. One way to inspect the hose and other parts affected by the blasting is to put on your protective clothing. Then pressurize the system and close the nozzle shut off the valve (31). Listen for air leaks, fix any leaks before operating. You can also spot places in the hose where the wall is getting very thin. These show up as blisters in the hose; if you find such a blister, get a new hose immediately. If that blister breaks, the abrasive will come out of the side of the hose.**

AIR COMPRESSOR RECOMMENDATION:

To permit efficient operation of your air compressor, follow these guidelines:

- 1. Use a smaller size nozzle to control the demand of air.**
- 2. Do not blast continuously. Stop blasting operation periodically to allow the compressor to cool. No compressor is designed to constantly run at full RPM. Use 70% of the rated output.**
- 3. Use a minimum 1/2" air hose or metal piping from your air compressor to the blaster. If your compressor is creating an excessive amount of moisture, we recommend using a water trap or a moisture separator.**
- 4. The air compressor should be drained at the bottom of the supply tank through a drain valve and should be blown down daily. It is not unusual to drain three or four gallons of water from the supply tank on a high humidity day. An additional supply tank will help.**
- 5. Keep dust and media created by blasting away from the air compressor unit. Observe maximum air pressure requirements for the blaster and either set your compressor to run within these limits or use a pressure regulator valve to reduce the air pressure to the appropriate range.**

ABRASIVE (MEDIA) USAGE:

- 1. If moisture is in the media it will eventually damage the blaster tank or plug the system. Keep the media and compressor air dry to avoid this problem.**
- 2. If media is moist, screen it and dry it before using.**
- 3. Do not leave media in the tank after blasting because it can absorb moisture and impair blasting performance.**
- 4. Store media in a dry place; keep media off the ground or concrete floors. Put it on a wooden skid.**
- 5. If the humidity is excessively high, it may not be advisable to blast at that time.**
- 6. Consider using different grades or different types of media to prevent nozzle clogging due to high moisture content.**
- 7. DO not use sand.**

OPERATING INSTRUCTIONS

OPERATING TECHNIQUE:

1. Connect air hose to air inlet valve. Manufacturer recommends using minimum incoming air hose of 1/2" I.D. using an air hose smaller than 1/2" I.D. will restrict air volume and result in poor unit operation. Prior to Injection of air, be certain air inlet valve and nozzle valve are in the OFF position. With Deadman Valve closed and filler plug tight, open air inlet valve allowing air to pressurize. Operating range of unit is 40 to 110 PSI
Note: For proper nozzle selection, refer to nozzle selection chart on page 11. after proper nozzle selection, insert nozzle into retainer base. Set against washer and slide retainer nut over nozzle and tighten by hand.
2. Manufacturer recommends a fine grade abrasive with granular size similar to that of table salt. This assures proper flow and reduces the possibility of nozzle obstruction.
3. With the blaster pressurized and abrasive flow regulator valve at base of unit closed, open ball valve allowing air to flow through by-pass hose to base of the unit. Then holding the abrasive hose by nozzle retainer housing with nozzle directed away from unit and operator, quickly squeeze the Deadman Valve fully open and adjust the regulator valve at base of tank to bleed the abrasive into air flow. Slowly open regulator valve until abrasive material is slightly visible. Once the regulator flow valve is adjusted to the desired setting, further adjustment should only be required when changing grade of abrasive material or when a nozzle with a different I.D. is used. Opening regulator valve too far will result in a clogged hose or nozzle.

For best performance, the Deadman Valve should be opened and closed quickly

WARNING!

Disconnecting hose while Unit is under pressure could cause serious injury or death. Use safety lock pins and safety cables in all coupling connections to help prevent hose couplings from accidental disconnection.

If twist-on type air hose couplings are used, they must be secured by safety lock pins or wires to prevent accidental disconnection while under pressure. Hose disconnection while under pressure could cause serious injury.

Warning! Do not fill the pressure vessel to within six (6) inches of the top of the vessel. If a hose is accidentally disconnected during use media spray may occur.

See respiratory related WARNINGS at the beginning of the manual.

Coal Slag

Coal Slag is used when paint and rust has to be removed from steel, such as Car bodies, tanks or heavy machinery. **Coal Slag** is superior to silica because It only has **0.1%** free silica, is faster cutting, can be re-used, is moisture free, and will not pack or absorb moisture.

Steel Grit

Steel grit is extremely fast cutting on rusty metal and hard to remove paint. Steel Grit is popular because it leaves a very smooth finish. It is also comparable in Price to most other specialty abrasives. Steel Grit is recommended in reclaim Systems or cabinets.

Glass Bead

Glass Bead is used in creating a satin or matte finish. Glass Bead is recommended in reclaim systems or cabinets.

Aluminum Oxide

Aluminum Oxide is a high quality abrasive that is sharper than sand (not recommended) and cuts twice as fast as sand. It leaves a smooth textured finish with no pits. Aluminum Oxide is rougher than glass bead and can be used over and over again. It is one of the most economical abrasives you can use in any reclaim systems or cabinets.

Plastic Grit

Primarily used to strip aluminum and fiberglass. Great for stripping paint. Light oxidation and surface rust. Recommended for use in blast cabinets because it creates very little dust. Works quickly, last a long time and increases visibility within the cabinet.

AIR ABRASIVE SUPPLY REQUIREMENTS

Abrasive blasting requires a large volume of air at high pressure. The efficiency of your abrasive blaster can be adversely affected by the use of too small an air supply hose, insufficient air pressure or an overly large nozzle.

Hose ID	Hose Length	Nozzle ID	CFM@ 110 PSI	Abrasive Use Per Hour
3/8"	50ft	3/32"	6	60 lbs
3/8"	25ft	7/64"	12	100 lbs
1/2"	50ft	1/8"	15	150 lbs
1/2"	25ft	9/64"	20	200 lbs

We recommend that air pressure in the range of 65/110 PSI will provide the best Results.

LOADING ABRASIVES INTO THE TANK

1. Check your abrasive to be sure it's dry, and won't clog the metering valve (30), abrasive outlet pipe (12), hose (21), or other components.
2. Put on the protective clothing, full hood and MSHA/NICOSH approved Respirator.
3. Turn the air supply valve (31) to the off (horizontal) position.
4. Push down to open the nozzle DEADMAN valve (25).
5. Watch the pressure gauge (9) and make sure it reads zero pressure.
6. Remove the filler cap (4) from the top of the tank.
7. Insert the funnel (19), and pour the abrasive into the funnel. Be sure to get enough into the tank to do the job at hand. But if this is a big job, fill the tank only 3/4 full, and reload as needed to finish the work.

TIP: if the humidity is 90/100%, the water trap (9) won't be able to trap all of the moisture in a 3/4 tank. Better to reduce the amount of abrasive, load more frequently, and empty the water trap more open. This will reduce the possibility of clogging the bottom of the tank or the line.

8. with the correct amount of abrasive in the tank, close the filler cap (4).

- 9. Close the nozzle shut-off valve (30), and open the air supply valve (31).**
- 10. Listen for air leaks at the filler cap as you begin to pressurize the tank from the compressor. Fix any leaks before operating.**

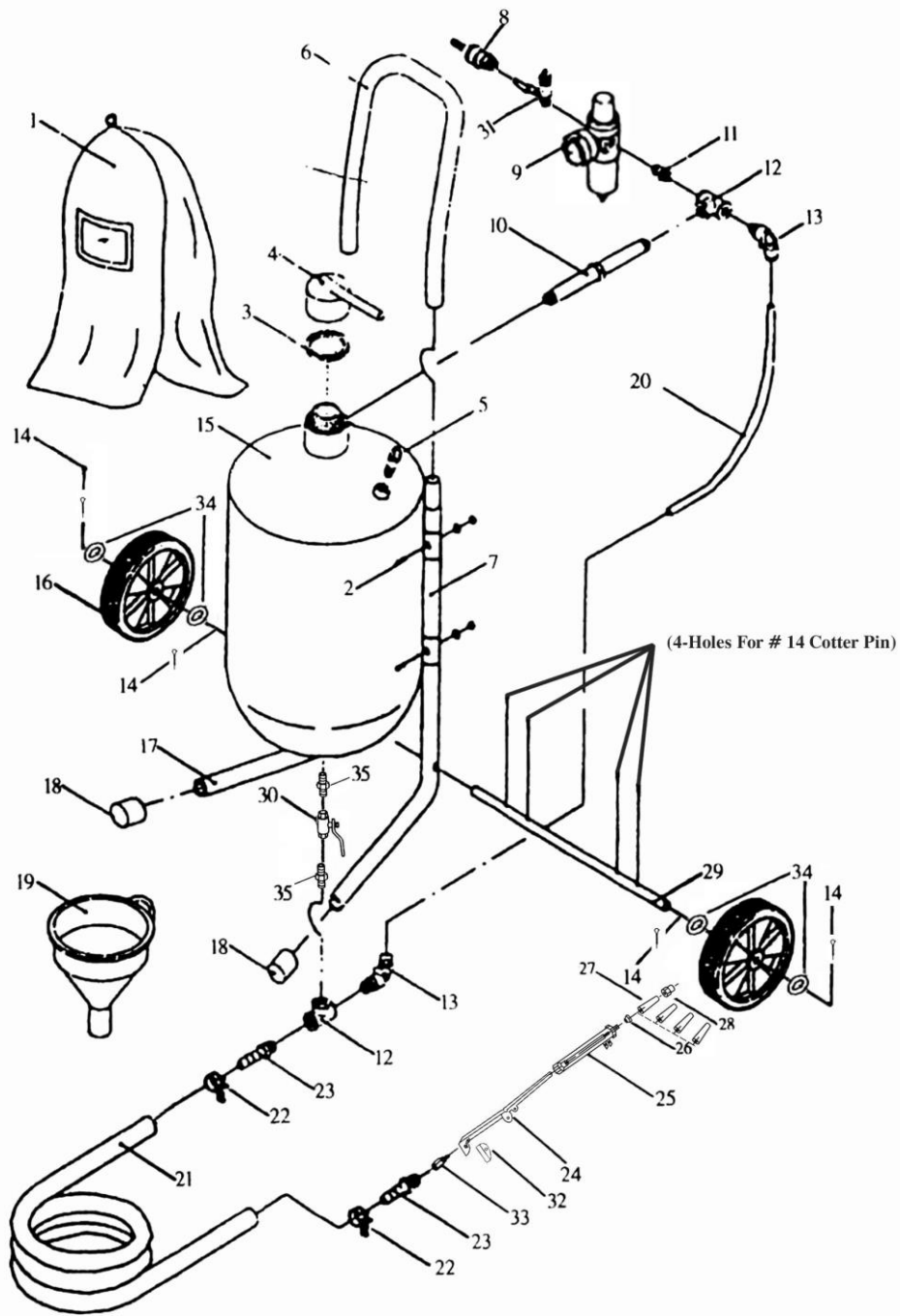

EXPLODED VIEW FOR PARTS LIST (5-GAL)

Drawing for steps beginning with step number one.

CAUTION

1. Pay particular attention to the ABRASIVE HOSE (#21), the DEADMAN VALVE (#25), and the NOZZLE (#27) as they will wear out much more quickly than the other pieces.
2. The ABRASIVE HOSE needs replacing when its sidewalls develop leaks or show blisters in the surface. Do not use if any of these problems are present.

Parts list (5-GAL)

Part No.	Description	QTY	Part No.	Description	Qty
1	Hood	1	18	Leg End Cap	2
2	Screw	4	19	Funnel	1
3	O-Ring	1	20	Air Hose	1
4	Tank Filler Cap	1	21	Abrasive Hose	1
5	Safety Valve	1	22	Hose Clamp	2
6	Handle Bar	1	23	Hose Adaptor	2
7	Left leg	1	24	Trigger Assy	1
8	Connector	1	25	Deadman Handle	1
9	Air Pressure Adjuster	1	26	Rubber Gasket	1
10	Joint Pipe	1	27	Ceramic Nozzle	4
11	Nipple Connector	1	28	Front Nut	1
12	Intake Manifold	2	29	Axle	1
13	Elbow Connector	2	30	Abrasive Metering Valve	1
14	Cotter Pin	4	31	Ball Valve	1
15	Tank	1	32	Sealing Block	1
16	Wheel	2	33	Deadman valve adaptor	1
17	Right Leg	1	34	Washer	4
			35	NIPPLE CONNECTOR	2

NOZZLES: A=9/64"

B=1/8"

C=7/64"

D=3/32"

TROUBLESHOOTING TIPS

PROBLEM/CAUSE

Surging of blast flow:

Air pressure too low
Too much media

Excessive media consumption:

Media valve open too far
Air pressure too low

Clogging and plugging of blast flow:

Debris in media
Media size too large
Nozzle plugs
Nozzle plugs
Wet media

Moisture in abrasive media:

Wet media
Water in air
Water in tank

Humid weather:

Moderate humidity
Moderate humidity
High humidity

Overtaxed compressor:

Compressor too small
Nozzle size too large
Too many leaks in plumbing
Holes in abrasive hose
Air filter on compressor plugged

Lack of air pressure:

Compressor too small
Supply valves not on full position
Nozzle size too large
Leaks in plumbing
Holes in abrasive hose
Air filter on compressor plugged
Urethane gasket worn or dirty

Lack of abrasive flow:

Blaster tank empty
Moisture in media
Not enough air pressure
Abrasive hose kinked
Debris in media

POSSIBLE SOLUTION

See "Lack of Air Pressure"
Adjust media valve

Close slightly
Check pressure gauge

Purge and screen
Use smaller grit size
Use larger nozzle
Adjust media valve
Dry media, drain water from air

Change or use dry media
Drain water from air lines
Empty, dry out and refill

Keep media as dry as possible
Use drier or moisture separator
Avoid that period of use if possible

Restrict time used
Use smaller size
Seal and tighten plumbing
Replace hose
Clean

Use smaller nozzle
Open valves
Use smaller size
Seal and tighten plumbing
Replace hose
Clean filter
Clean or replace gasket

Fill tank
Dry media
Check system
Straighten hose
Clean or screen media



Disclaimer of Warranties. ALLSOURCE ("Seller") makes no warranties with respect to any goods delivered to Buyer or users except as specifically set forth within this manual. ALLSOURCE . MAKES NO IMPLIED WARRANTIES OF MERCHANTABILITY OR FITNESS FOR A PARTICULAR PURPOSE WITH RESPECT TO ANY OF THE GOODS, AND ALLSOURCE . EXPRESSLY DISCLAIMS ANY IMPLIED WARRANTIES AGAINST INFRINGEMENT. ALLSOURCE . WARRANTIES SHALL NOT APPLY TO ANY DAMAGE OR NON-CONFORMITY RESULTING FROM THE NEGLIGENCE OF IMPROPER ASSEMBLY OR USE OF ANY GOODS BY USERS OR BUYER OR ITS EMPLOYEES OR AGENTS, OR FROM ALTERATION OR ATTEMPTED REPAIR BY ANY PERSON OTHER THAN ALLSOURCE . ALL USED, REPAIRED, MODIFIED OR ALTERED ITEMS ARE PURCHASED AS-IS AND WITH ALL FAULTS.

Indemnification Agreement. Buyer agrees, to the fullest extent permitted by the law, to fully indemnify, hold harmless, and defend Seller, its parent, subsidiary, and affiliated companies, its owners, officers, directors, employees, agents, representatives and insurers (collectively, "Indemnities") from and against any and all claims, demands, suits, damages, judgments of sums of money, losses and expenses, including but limited to attorney's fees and costs (collectively "referred to herein as "Claims") arising out of or resulting from any bodily injury, sickness, disease or death or injury to or destruction of tangible property, arising out of or resulting from the use, sale or distribution of any and all products purchased from Seller by Buyer, regardless of whether or not such claim arises in whole or in part out of Seller's alleged fault, including but not limited to Seller's negligence, strict liability, products liability, breach of warranty or any other act or omission. Buyer expressly waives any and all immunity from suit by Seller, its parent, subsidiary, and affiliated companies, and its owners, officers, directors, employees, agents, representatives and insurers, by operation of any workers' compensation law or statute. **By purchasing from ALLSOURCE Buyer acknowledges and represents that Buyer has read, fully understands and agrees to the Indemnification provisions set forth above.**

