

Instruction Manual



VT6008 – Pistol Grip Flux Chipper



Viking Air Tools

DIVISION OF S&H INDUSTRIES, INC.

5200 Richmond Road • Cleveland, OH 44146

Phone 216-831-0550 • Toll Free 800-253-9726

Fax 216-831-9573 • www.shindustries.com

E-Mail: www.service@shindustries.com

SAFETY INSTRUCTION

1. GENERAL SAFETY RULES

READ OPERATING INSTRUCTION

Do not attempt to operate until you have thoroughly read and completely understand all instructions, rules, etc. contained in this manual. Keep owners manual and review frequently for continuous safe operation. Always become familiar with all the instructions and warnings before operating any pneumatic tool. This manual contains information that is important for you to know and understand.

WARNING

Some dust created by power sanding, sawing, grinding, drilling and other type of tool running can cause illness or death. Your risk from these exposures varies, depending on how often you do this type of work. To work with approved safety equipment, always wear MSHA/NIOSH approved, properly fitting mask or respirator when using such tools. Never leave operating tool unattended. Disconnect air hose when tool is not in use.

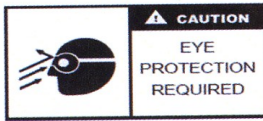

ALWAYS WEAR APPROVED EYE PROTECTION

Always wear ANSI approved safety glasses. Never take safety glasses off while air tool is in use, disconnect air supply line before removing protective eye wear.

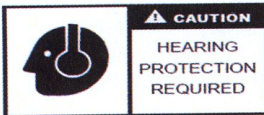

ALWAYS WEAR HEARING PROTECTION

Hearing protection should be used when the noise level exposure equals or exceeds an 8 hour time-weighted average level of 85 DB. Process noise, reflective surface, other tools being operated nearby, all add to the noise level present in your work area. If you are unable to determine your noise level exposure, we recommend the use of hearing protection.

AIR SUPPLY REQUIREMENT

Supply the tools with 90 PSI (6.2 bar) for maximum tool performance and take your reading while the tool is running. Higher pressure drastically reduces tool life. Connect tool to air line using approved, hose and fittings.

Check the condition of air line accessories, and drain out the water from the separators and air line to keep air supply system cleaning and drying.

Use proper couplers, nipples, hoses, pipes and fitting for the tool.

1.2 IMPORTANT SAFETY INSTRUCTIONS

General: To reduce the risks of electric shock, fire and injury to persons, read all the instructions before using this pneumatic tool.

Work area:

1. Keep the work area clean and well lighted. Cluttered benches and dark areas increase the risks of electric shock, fire and injury to persons.
2. Do not operate the tool in explosive atmospheres, such as in the presence of flammable liquids, gases or dust. The tool is able to create sparks that can result in ignition.
3. Keep bystanders, children, and visitors away while operating the product. Distractions can result in loss of control of the tool.

Personal Safety:

1. Stay alert. Watch what you are doing and use common sense when operating this product. Do not use the product while tired or under the influence of drugs, alcohol, or medication. A moment of inattention while operating the tool increases the risk of injury to persons.
2. Dress properly. Don't wear loose clothing or jewelry. Contain long hair. Keep hair, clothing, and gloves away from moving parts. Loose clothes, jewelry, or long hair increases the risk of injury to persons as a result of being caught in moving parts.
3. Remove adjusting keys and wrenches before turning the tool on. A wrench or a key that is left attached to a rotating part of the tool increase the risk of personal injury.
4. Do not over reach. Keep proper footing and balance at all times: Proper footing and balance enable better control of the tool in unexpected situations.
5. Use Safety equipment. A dust mask, non-skid safety shoes and hard hat must be used for the applicable conditions.
6. Always wear eye protection.
7. Always wear hearing protection when using the tool. Prolonged exposure to high intensity noise may cause hearing loss.
8. Disconnect the product from the air source before making any adjustments.
9. Avoid unintentional starting. Be sure the switch is off before connecting to the air supply. Do not carry the tool with your finger on the switch or connect the tool to the air supply with the switch on.
10. Accessories must be rated for at least the speed of the tool marked on the tool label. Wheels and other accessories running over the rated speed can fly apart and result in a risk of injury to persons.

2. FUNCTION OF MACHINE

Air tool designed to chip weld flux with a chisel attachment.

3. INSTALLATION

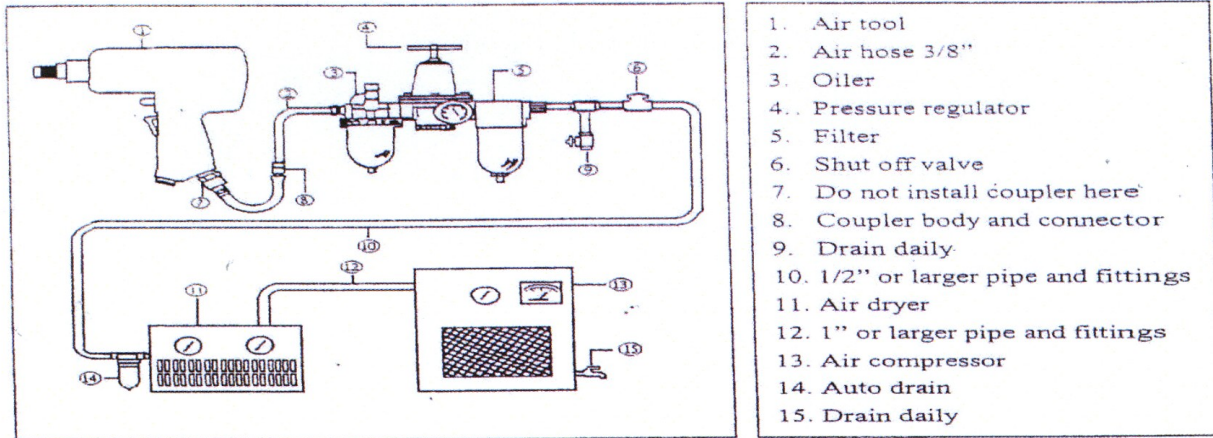

AIR SUPPLY REQUIREMENT

Supply the tools with 90 PSI (6.2 bar) for maximum tool performance and take your reading while the tool is running. Higher pressure drastically reduces tool life. Connect tool to air line using approved, hose and fittings, as per diagram.

Check the condition of air line accessories, and drain out the water from the separators and air line to keep air supply system cleaning and drying. Provide for clean dry compressed air, with a suitable oil mixture.

Use the correct air treatment, unit: filter, pressure regulator and lubrication.

Use proper couplers, nipples, hoses, pipes and fitting for the tool. Quick-disconnect coupling and hose air flow should have sufficient capacity. We recommend an air hose with an inner diameter 10mm (3/8").

4. OPERATION

TOOL OPERATION AND CONNECTION

1. Turn air compressor on and allow air tank to fill.
2. Set the air compressor's regulator to 90 PSI. The tool operates at the maximum 90-PSI pressure.
3. Before operation of the equipment, put a few drops of air tool oil in the air inlet opening of the pneumatic tool.
4. Assemble any accessories and connections on the tool.
5. Connect air line to the tool.
6. Depress trigger to operate tool.
7. Release trigger to stop tool.

5. MAINTENANCE

5.1 DAILY MAINTENANCE

1. Regularly clean and dry filter and the pneumatic tool air inlet opening.
2. Re-lubricate any quick-disconnect couplings on the system to prevent jamming.
3. Drain condensation from air filter and from the compressor on a daily basis.
4. In order to avoid rust formation and to minimize wear, clean and lubricate the tool after each use.

5.2 STORAGE

Avoid storing the tool in a location subject to high humidity. Should the pneumatic tool not be used for an extended period of time, it is recommended to store in a clean and dry place. Before storing and after operation, oil the tool air inlet with air tool oil and run it for a short time.

5.3 DISPOSAL

If the tool is too seriously damaged to be used anymore, dispose of the tool in a resource recycling can.

5.4 ORDERING SERVICE PARTS

For further operational and handling information or for replacement of parts and components. Contact who you purchased the tool from or their service division. When ordering parts and components, give each part number, name and quantity.

Specifications

VT6008



CFM	10
BPM	3000
STROKE LENGTH (Inch)	5/8
MAX PSI	90
NOISE DB	107
WEIGHT (Lbs.)	3.6
LENGTH (Inch)	10
MIN HOSE SIZE (Inch – I.D.)	3/8
AIR INLET (Inch - NPT)	1/4
VIBRATION	8.7
WARRANTY	1 Year Limited Warranty

VT6008

Pistol Grip Flux Chipper

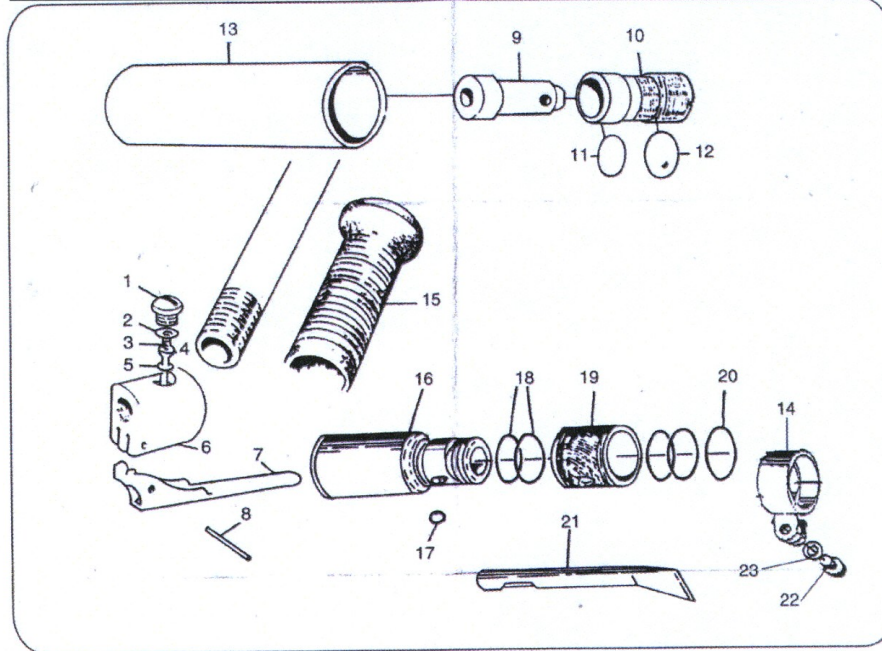

PARTS LIST

Index No.	Name Of Parts	Per Set	Index No.	Name Of Parts	Per Set
1	Valave Cap	1	13	Pistol Handle Housing	1
2	'O'Ring-Valve Cap	1	14	Clamp Only	1
3	Valve Spring	1	15	Rubber Handle Grip	1
4	Valve Stem	1	16	Cylinder Body	1
5	'O'Ring-Valve Seat	1	17	Ball(7/16)	1
6	Valve Body	1	18	"O"Ring(P24)	4
7	Throttle Lever	1	19	Chisel Cover	1
8	Roll pin	1	20	Snap Ring	1
9	Piston	1	21	Chisel	1
10	Cylinder	1	22	Hex Socket Bolt (H8X20)	1
11	'O'Ring(P26)	1	23	Washer	1
12	'O'Ring(P26)	1			