



PARTS LIST

MASKER: 36"

Part #78003

PART#	DESCRIPTION	QUANTITY
10676	1/4"-20 X 1 1/2" Bolt	2
10675	1/4"-20 X 2" Bolt	2
10217	1/4"-20 X 3" Bolt	2
10218	1/4" Flat Washer	14
10201	1/4"-20 Hex Nut	4
10178	1/4"-20 Lock Nut	4
10678	1/4"-20 X 2" Knob	2
10688	Tubing Cap	4
10680	Paper Bar Collar with Wing Nut	2
10677	Paper Bar Washer	2
10222	Paper Bar Spring	1
10672	Tape Spool	2
10689	S - Hook	2
10694	Extension Spring	1
10696	Cutter Bar	1
10692	Paper Bar	2
10683	Leg	2

Add-A-Roll Kit! You may also order the Add-A-Roll kit which includes 1 Paper Bar Spring, 2 Paper Bar Washers and 2 Collars with Wing Nut. This kit allows you to run 2 paper rolls simultaneously. **Order part number 78008.**

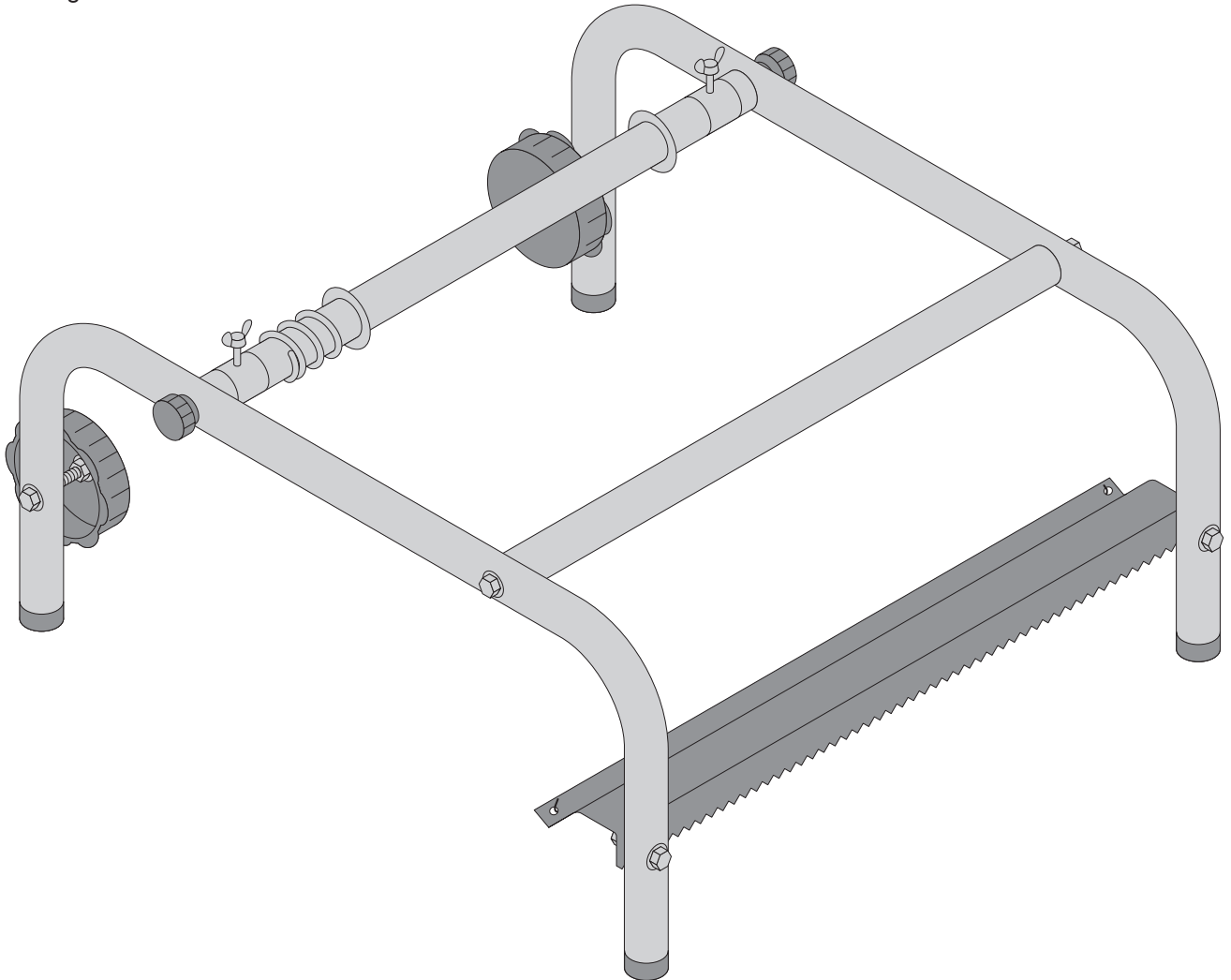

STEP 1. **Assemble the main frame tubing** using 1/4"-20 X 2" bolts and 1/4" washers. **Note the locations of all punched holes** in all tubing to ensure proper assembly. Assemble and install the Tape Spools. Follow the diagram below closely to ensure proper assembly of the Tape Spools. The order of the hardware is identical for both sides.

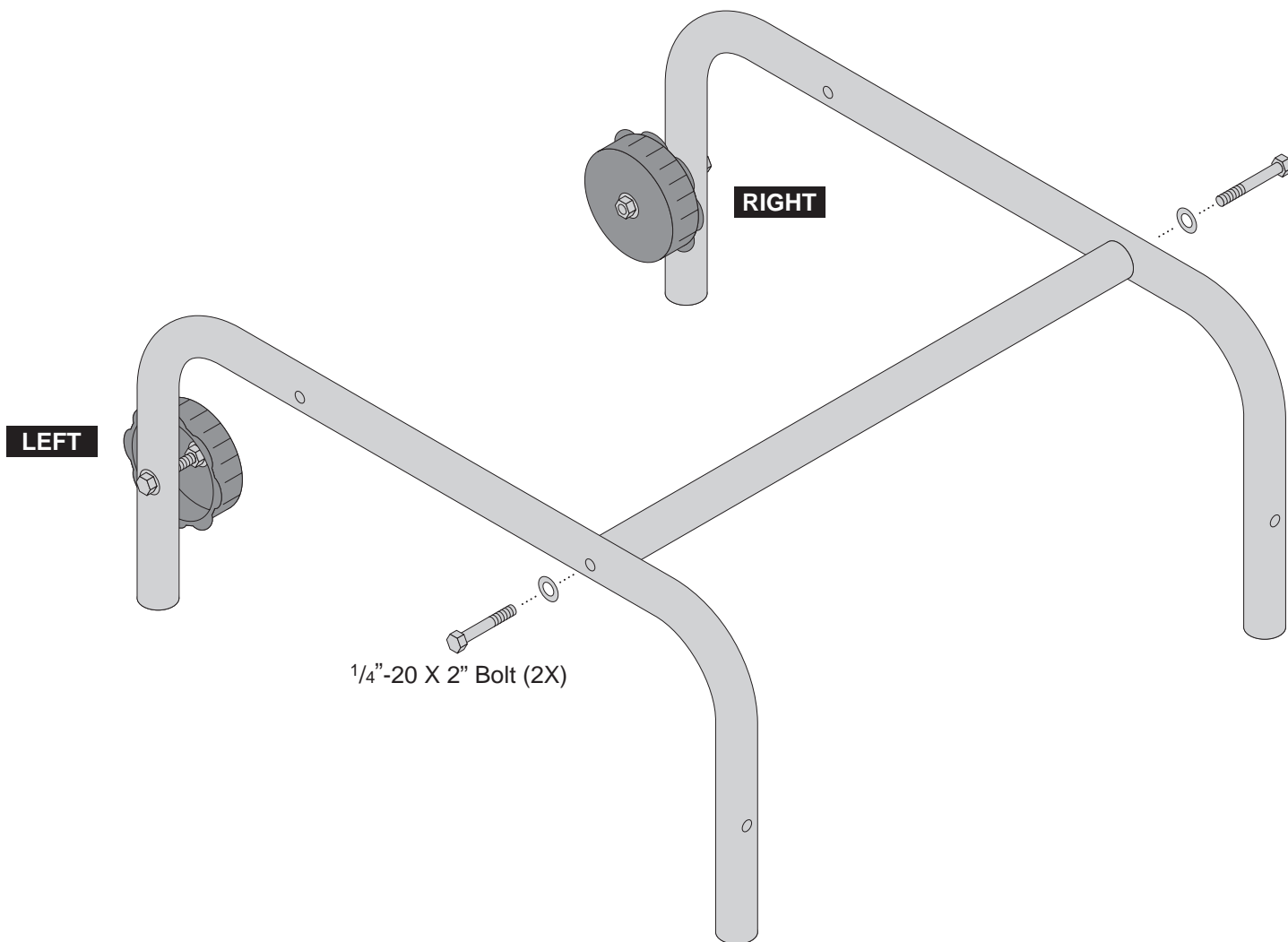
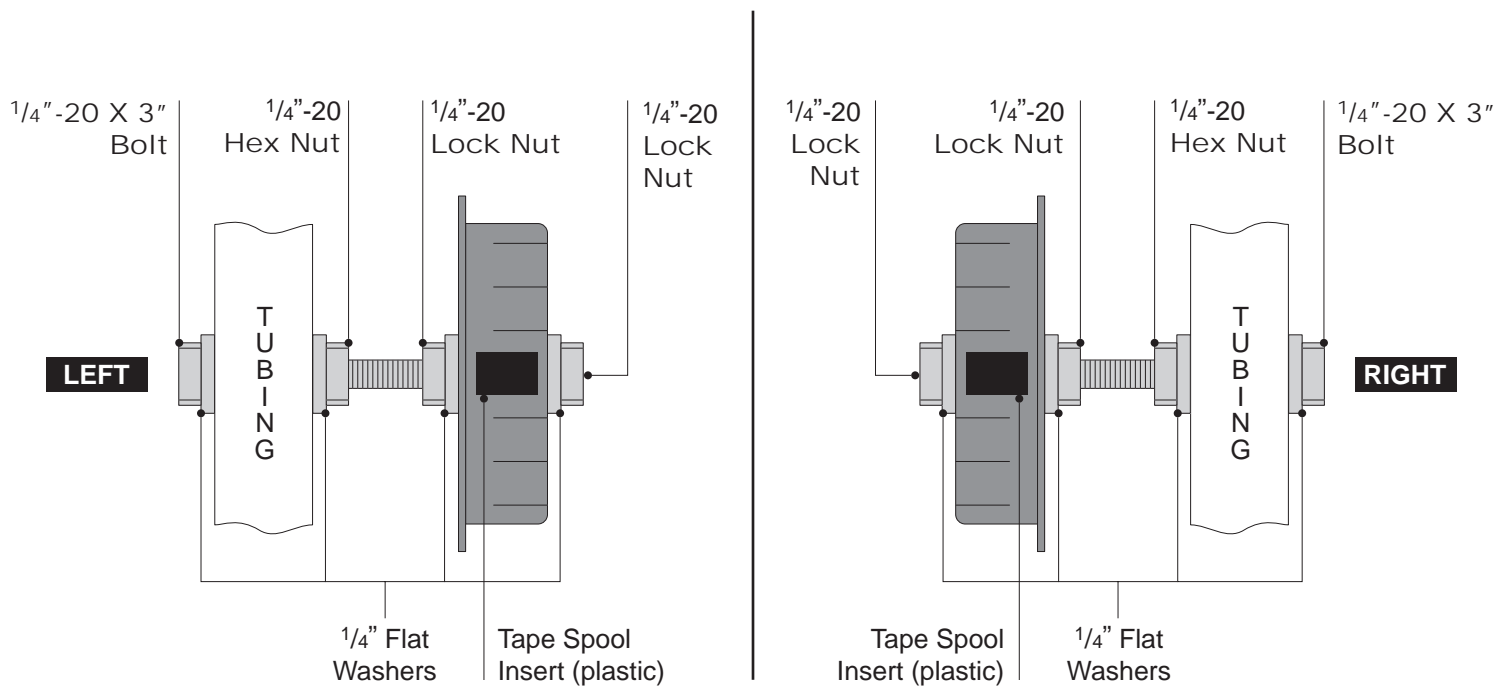

STEP 2. **Assemble the rear Paper Bar** following the diagram below. Attach Paper Bar to the main frame with the attached knobs. Next, install Cutter Bar as illustrated below. Ensure that Cutter Bar teeth are facing forward and down as shown. Install Paper Bar Spring on the **BACK SIDE** of the Cutter Bar. Lastly, install the 4 Tubing Caps to the bottom of tubing to aid in traction and stability.

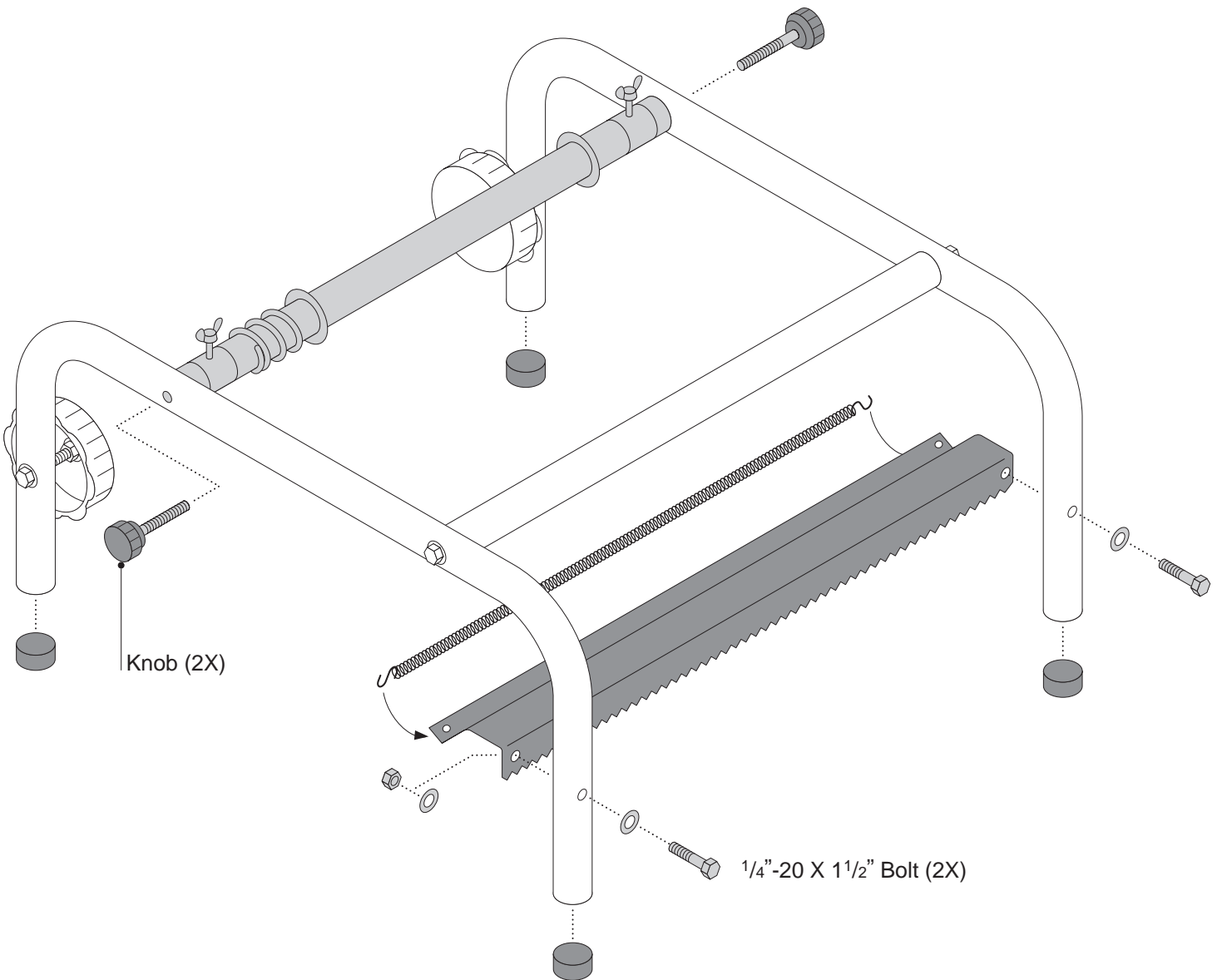
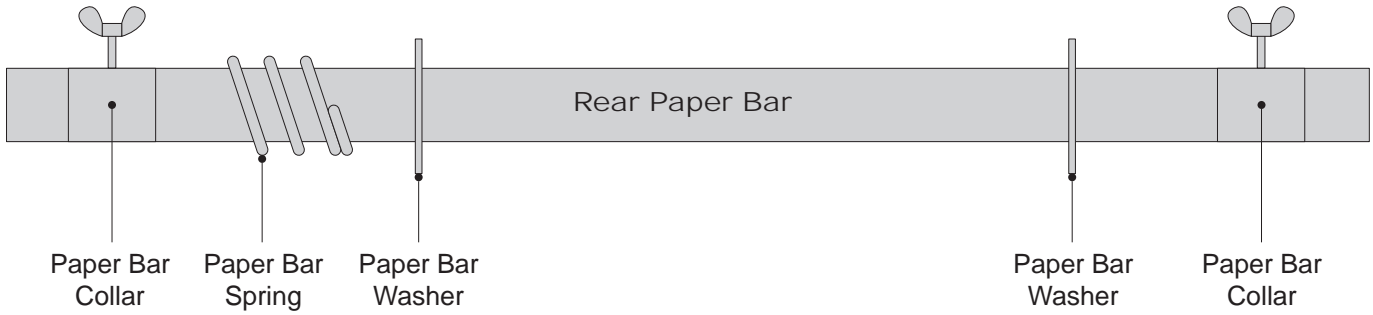

Paper roll and tape spool placement. Two Tape Spools are included so that you may conveniently run your tape along either end of your paper roll by simply adjusting the location of the paper roll along the Paper Bar.

Apply pressure to Paper Bar Collar, Spring and Washer against paper roll and tighten wing nut to secure at desired tension.

Align paper roll so that half of the tape is on the paper and the other half hangs over.

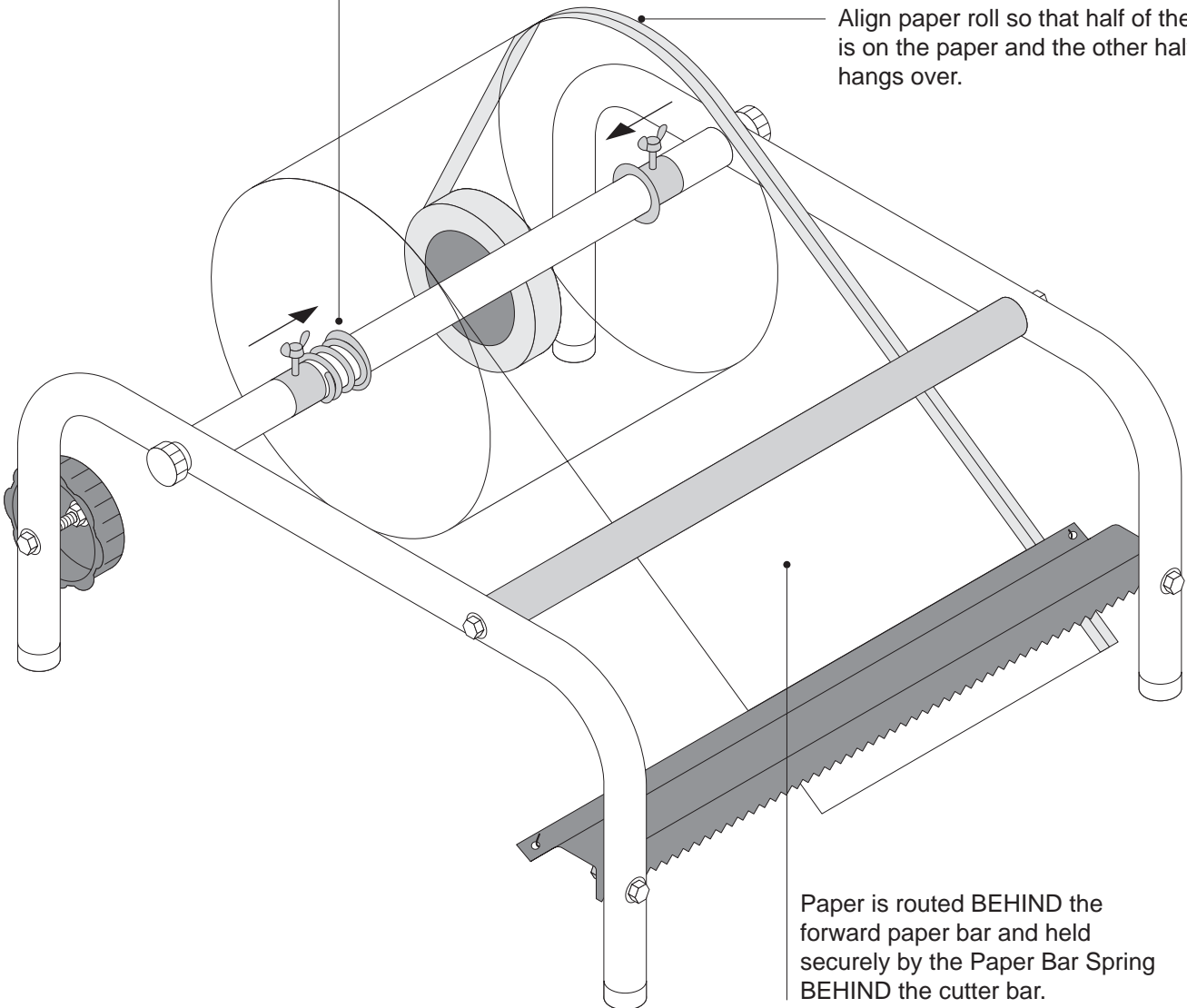

Paper is routed BEHIND the forward paper bar and held securely by the Paper Bar Spring BEHIND the cutter bar.

PART NUMBER BREAKDOWN for ORDERABLE PARTS

Add-A-Roll Kit! You may also order the Add-A-Roll kit which includes 1 Paper Bar Spring, 2 Paper Bar Washers and 2 Collars with Wing Nut. This kit allows you to run 2 paper rolls simultaneously. **Order part number 78008.**

